

DIMENSIONI D'INGOMBRO - OVERALL DIMENSIONS - DIMENSIONS D'ENCOMBREMENT - AUSSENABMESSUNGEN - DIMENSIONES DEL ESPACIO OCUPADO

1

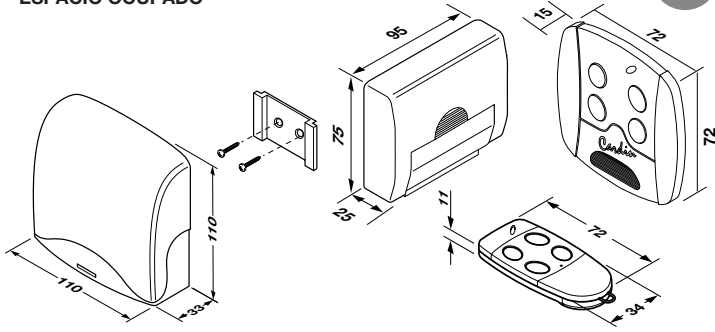

CAMBIO BATTERIA - CHANGING THE BATTERY - REMPLACEMENT DE LA PILE - BATTERIEWECHSEL - SUSTITUCIÓN DE LA PILA

2

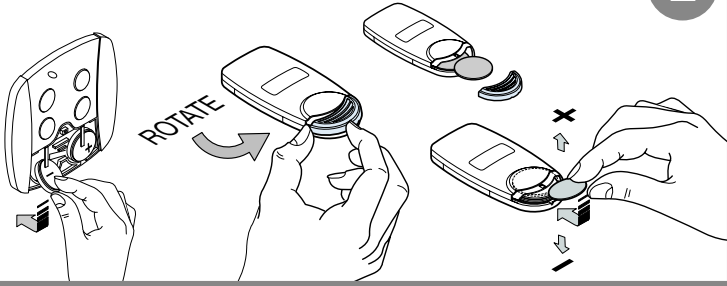

SELEZIONE DEI CANALI - CHANNEL SELECTION - DISPOSITION DES CANAUX - ANORDNUNG DER KANÄLE - DISPOSICION DE LOS CANALES

3

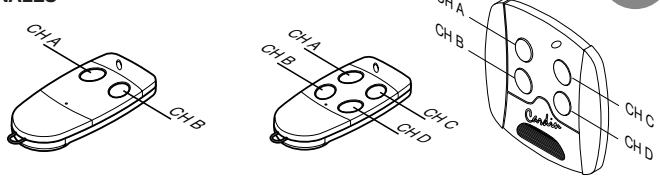

Esempio di selezione canali
Channel selection example
Exemple de sélection de canal
Beispiel der Kanalwahl
Ejemplo de selección canal

CH-1 = CHA (Tx)
CH-2 = CHD (Tx)

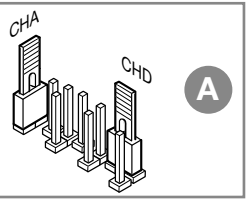

COLLEGAMENTO ELETTRICO - ELECTRICAL CONNECTION - BRANCHEMENT ÉLECTRIQUE - KLEMMLEISTANSCHLÜSSE - CONEXIONES ELECTRICAS

4

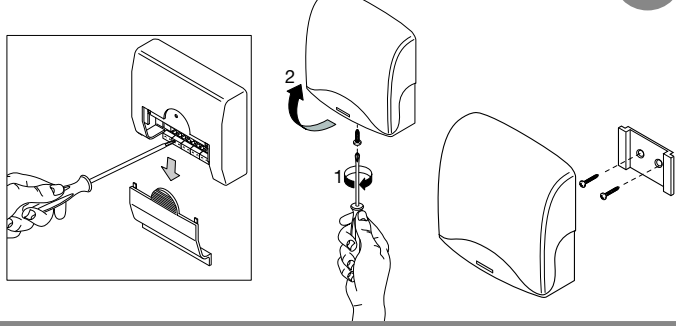

PROCEDURA DI MEMORIZZAZIONE/CANCELLAZIONE CHANNEL MEMORISATION/CANCELLATION PROCEDURE PROCÉDÉ DE MÉMORISATION/EFFACEMENT SPEICHER-/LÖSCHUNGSVERFAHREN PROCEDIMIENTO DE ALMACENAMIENTO/BORRADO

5

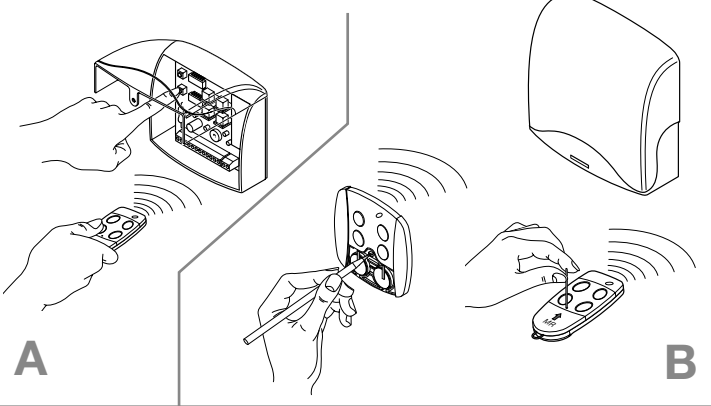

RICEVITORE IN CASSETTA OUTDOOR RECEIVER RÉCEPTEUR AVEC BOÎTIER AUSSENEMPFÄNGER RECEPTOR CON CONTENEDOR

6

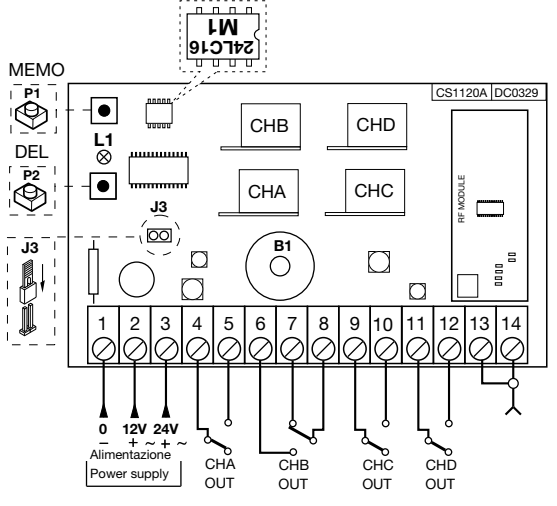

RICEVITORE A SCHEDA AD INNESTO DIRETTO SLOT-IN RECEIVER CARD RÉCEPTEUR À CARTE EMBROCHABLE STECKEMPFÄNGER RECEPTOR CON TARJETA DE INSERCIÓN DIRECTA

7

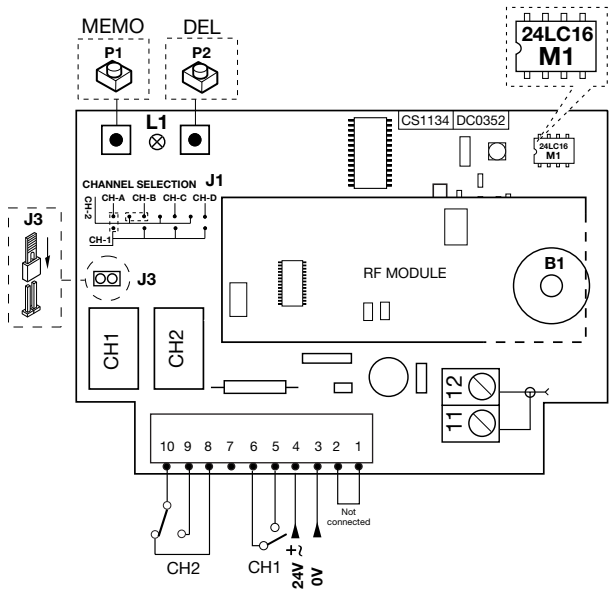

RICEVITORE MINI MINI RECEIVER MINI RÉCEPTEUR MINIEMPFÄNGER MINI RECEPTOR

8

